

Introduction



Based on the decades of experience of Pizzato Elettrica in the field of industrial safety and automation, the CS AR series of safety modules for lifts has been developed.

All CS series safety modules are implemented with cutting edge technology, and attention to detail.

They are produced on the premises of Pizzato Elettrica, at Marostica (in Italy), using special SMT (surface mount technology) assembly lines that are able to operate with lead-free technology. This meets eco-compatibility requirements laid down by the RAEE and RoHS Directives.

Maximum safety level

PL e + SIL 3

The safety modules of the CS series are equipped with redundant electronics. They enable the construction of circuits with the highest safety levels: PL e according to EN ISO 13849-1 and SIL 3 according to EN 62061.

Mounting on DIN rails

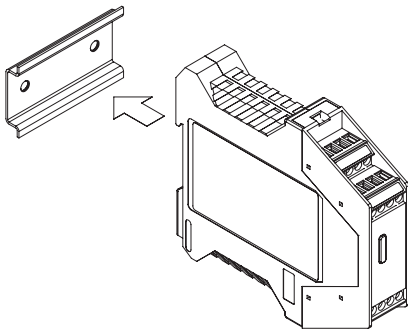

The housings of all CS series safety modules are suitable for DIN rail mounting and are compact (22.5 or 45 mm wide) to minimize the overall dimensions inside the control cabinets.

Fast wiring with removable connectors

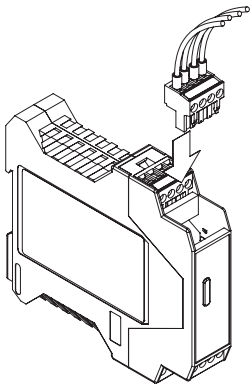

The CS series safety modules can be ordered as versions with screw terminals, or with removable connectors and screw or spring terminals.

The versions with removable connectors are faster and easier to wire and install.

Furthermore, should a damaged module require replacement, machine downtimes are significantly reduced.

Compliant with EN 81-20 standard

EN 81-20

The CS series of safety modules for lifts has been subjected to testing carried out by notified bodies, which

have confirmed compliance with technical standard EN 81-20 on the construction and installation of lifts for the transport of persons and goods.

These devices can therefore be used for implementation of the following safety functions:

- levelling and re-levelling with doors open, in accordance with 5.12.1.4 of EN 81-20;
- detection of uncontrolled movements of the car and control of a device that stops and holds the car in accordance with 5.6.7.7 of EN 81-20, with a response time of 15 ms;
- monitoring of correct operation and release of the motor brake in accordance with 5.6.7.3 of EN 81-20;
- detection of uncontrolled movements of the car during levelling operations with doors open and control of a device that stops and holds the car in accordance with 5.6.7.7 of EN 81-20, with a response time equal to 15 ms.

Quality marks



All Pizzato Elettrica safety modules bear quality marks that confirm their fulfilment

of safety requirements and compliance with product directives in force in international markets.

Within the European Union, the CE marking is issued in accordance with the most recent version of the 2014/33/EU lift directive.

Final inspection of 100% of all products



To provide the user with a guarantee of the high quality standards of Pizzato Elettrica products, each safety module is tested individually using automated test stations, and identified by a unique serial number.

This process allows preventive identification of products displaying production defects, or deviations from standard operating parameters.

EC type-examination certificate



The EC-type examination certificate is issued by a Notified Body, and guarantees compliance with the safety requirements of the Machinery Directive and lift directive. The EC-type examination certificate guarantees to the customer,

that experts of a Notified Body have verified compliance with directives and continuously monitor the production process and check the conformity of products with the sample (type) verified during approval. A product that is awarded EC-type certification can be marketed with the CE symbol, followed by a four-digit number identifying the Notified Body.

Technical assistance



The technical department of Pizzato Elettrica supports installers of CS series safety modules with useful information before, during, and after the installation phase, in the most complex applications.

Selection diagram

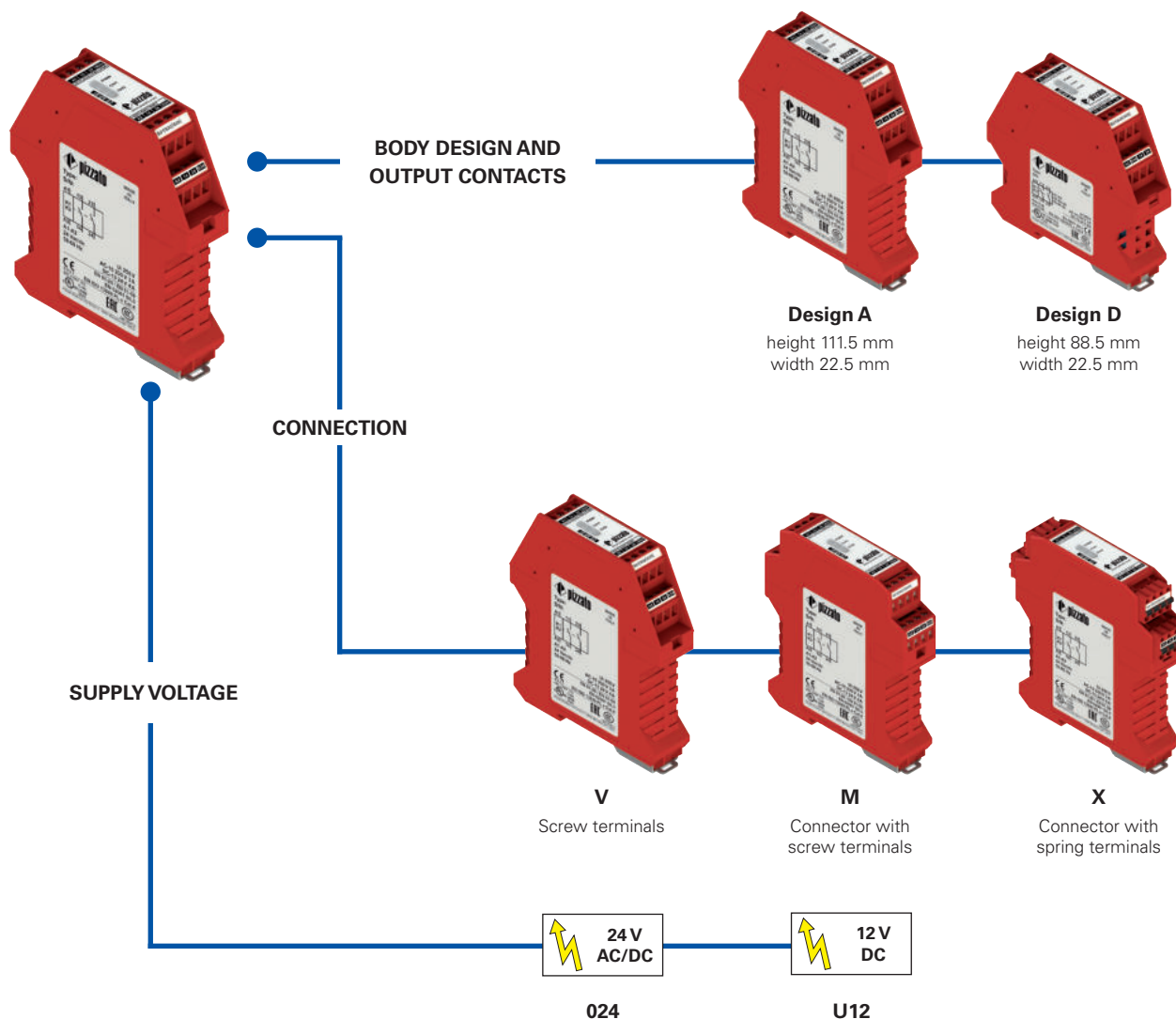

Code structure

Attention! The feasibility of a code number does not mean the effective availability of a product. Please contact our sales office.

CS AR-94V024

Output contacts and body design

91	2 NO safety contacts, 1 NO opto-decoupled signalling contact, design A
93	3 NO safety contacts, 1 NC auxiliary contact, design A
94	2 NO safety contacts, design A
95	2 NO safety contacts, design D

Connection type

V	Screw terminals
M	Connector with screw terminals
X	Connector with spring terminals

Supply voltage

024	24 Vac/dc
U12	12 Vdc (for CS AR-94 only)

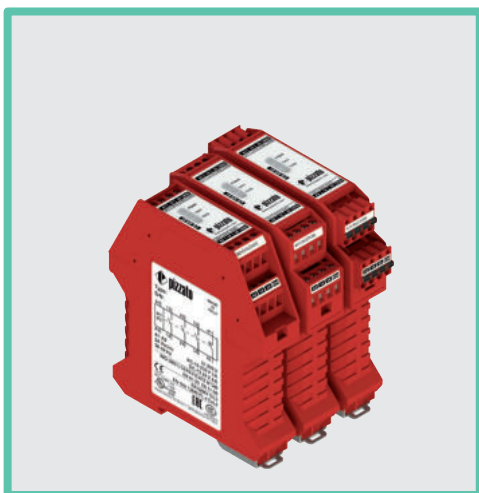

Module for floor levelling operations in lifts compliant to EN 81

Main features

- For safety applications up to SIL 3/PL e
- Choice between automatic start, manual start or monitored start
- Connection of input channels of opposite potentials
- Reduced housing width of 22.5 mm
- Output contacts:
2 NO safety contacts, 1 NO opto-decoupled signalling contact
- Supply voltage: 24 Vac/dc
- Insensitive to voltage dips

Utilization categories

Alternating current: AC15 (50...60 Hz)

U_e (V) 230

I_e (A) 3

Direct current: DC13 (6 oper. cycles/min.)

U_e (V) 24

I_e (A) 4

Quality marks:



EU-type examination certificate: IMQ n. 340

(EN 81-20:2014; EN 81-1:1998+A3:2009; EN 81-2:1998+A3:2009)

EC type examination certificate: IMQ CP 432 DM
(Machinery Directive)

UL approval: E131787

EAC approval: RU C-IT.AQ35.B.00454

CCC approval: 2013010305640211

Compliance with the requirements of:

Machinery Directive 2006/42/EC,

EMC Directive 2014/30/EU,

Lift Directive 2014/33/EU,

RoHS Directive 2011/65/EU.

Technical data

Housing

Polyamide housing PA 66, self-extinguishing V0 acc. to UL 94

Protection degree acc. to EN 60529:

IP40 (housing), IP20 (terminal strip)

Dimensions:

see page 133, design A

General data

SIL level (SIL CL):

up to SIL 3 acc. to EN IEC 62061

Performance Level (PL):

Up to PL e acc. to EN ISO 13849-1

Safety category:

Up to cat. 4 acc. to EN ISO 13849-1

MTTF_D:

227 years

DC:

High

PFH_D:

1.18 E-10

Ambient temperature:

-25°C ... +55°C

Mechanical endurance:

>10 million operating cycles

Electrical endurance:

>100,000 operating cycles

Pollution degree:

external 3, internal 2

Impulse withstand voltage (U_{imp}):

4 kV

Rated insulation voltage (U_i):

250 V

Overtoltage category:

II

Supply

Rated supply voltage (U_n):

24 Vac/dc; ± 15%; 50 ... 60 Hz

Max. DC residual ripple in DC:

10%

Power consumption AC:

< 5 VA

Power consumption DC:

< 2.5 W

Control circuit

Protection against short circuits:

PTC resistance, $I_h=0.5$ A

PTC response time:

Response time > 100 ms, release time > 3 s

Maximum resistance per input:

≤ 50 Ω

Current per input:

< 40 mA

Min. duration of start impulse t_{MIN} :

> 50 ms

Response time t_A :

< 120 ms

Release time t_{R1} :

< 20 ms

Release time in absence of power supply t_{R2} :

< 65 ms

Simultaneity time t_c :

unlimited

Response time starting from application of the supply: < 300 ms

Auxiliary signalling circuit

Auxiliary output (Y43-Y44):

1NO opto-decoupled

Rated operating voltage (U_o):

24 Vdc

Rated operating current (I_o):

25 mA

Rated impulse withstand voltage (U_{imp}):

4 kV

Release time t_{R2} :

< 1 ms

In compliance with standards:

EN 60204-1, EN ISO 13855, EN ISO 14118, EN ISO 12100, EN ISO 13850, EN 60529, EN 61000-6-2, EN 61000-6-3, EN 61326-1, EN 60664-1, EN 60947-1, EN IEC 63000, EN ISO 13849-1, EN ISO 13849-2, EN 62061, EN 81-20, EN 81-50, UL 508, CSA C22.2 n° 14-95, GB/T14048.5-2017.

Output circuit

Output contacts:

2 NO safety contacts,

Contact type:

forcibly guided

Material of the contacts:

gold-plated silver alloy

Maximum switching voltage:

230/240 Vac; 300 Vdc

Max. current per contact:

6 A

Conventional free air thermal current I_{th} :

6 A

Max. total current ΣI_{th}^2 :

36 A²

Minimum current:

10 mA

Contact resistance:

≤ 100 mΩ

External protection fuse:

4 A type F

The number and the load capacity of output contacts can be increased by using expansion modules or contactors. See pages 263-272 of General Catalogue Safety.

Code structure

CS AR-91V024

Connection type

V	Screw terminals
M	Connector with screw terminals
X	Connector with spring terminals

Supply voltage

024 24 Vac/dc

Features approved by UL

Rated supply voltage (U_n):	24 Vac/dc; 50...60 Hz
Power consumption AC:	< 5 VA
Power consumption DC:	< 4 W
Electrical ratings:	230/240 Vac 6 A general use C300 pilot duty

Notes:

- Use 60 or 75°C copper (Cu) conductor and wire size No. 30-12 AWG, stranded or solid.
- The terminal tightening torque of 5-7 lb in.
- Only for 24 Vac/dc versions: supply from remote Class 2 source or limited voltage limited energy.

CS AR-91 safety module

Pin assignment

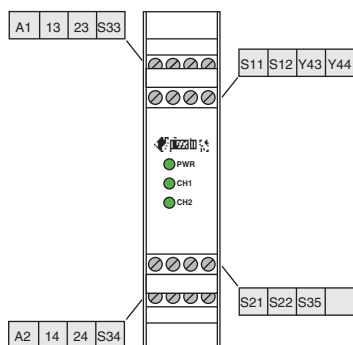

Voltage dips, short interruptions and voltage variations

The CS AR-91 safety module has a built-in voltage drop sensor which serves to protect and safeguard the internal state of the safety relays, in the event of dips or short voltage interruptions. This is to prevent unwanted switching states in relation to the state of the inputs from occurring. When voltage is restored, the device continues to operate with a switching state that is consistent with the input signals. The safety module retains its normal function during voltage dips and brief interruptions; for longer voltage interruptions, the safety outputs open and reset themselves automatically during an automatic start if voltage is restored or – in the case of a manual or monitored start – require that the system be reset by the operator.

Internal block diagram

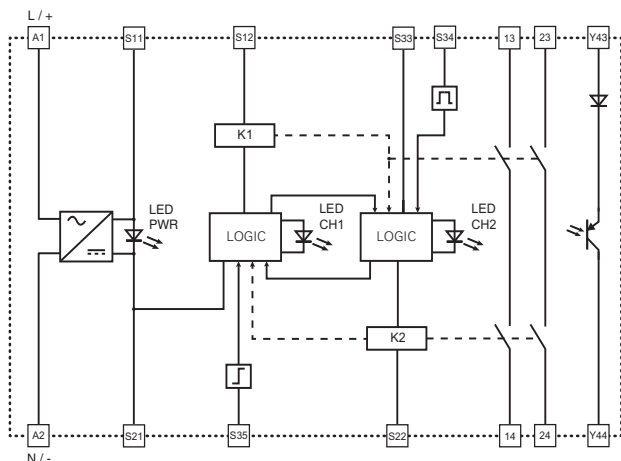

Input configuration

Input configuration with magnetic sensors

2 channels

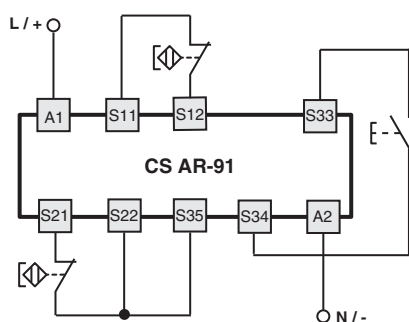

Function diagrams

Configuration with automatic start

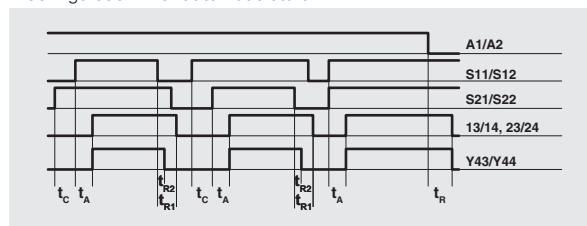

Configuration with monitored start

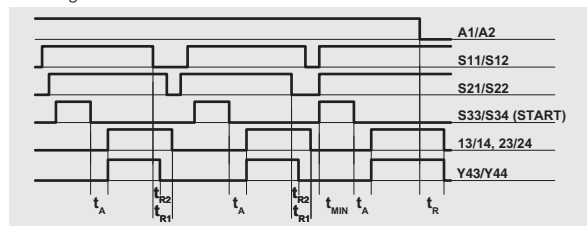

Configuration with manual start

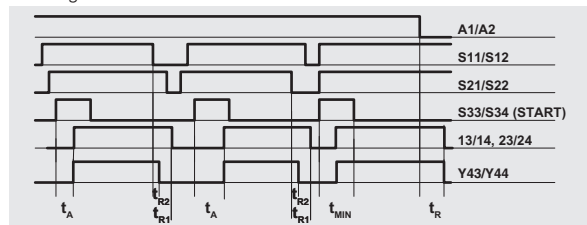

Legend:

t_{MIN} : Min. duration of start impulse
 t_C : simultaneity time
 t_A : response time
 t_{R1} , t_{R2} : Release time
 t_R : release time in absence of power supply

Notes:

The configurations with one channel are obtained taking into consideration the S11/S12 input only. In this case it is necessary to consider time t_{R1} referred to input S11/S12, time t_R referred to the supply, time t_A referred to input S11/S12 and to the start, and time t_{MIN} referred to the start.

Automatic start

With regard to the indicated diagrams, bridge the start button between S33 and S34 in order to activate the automatic start module.

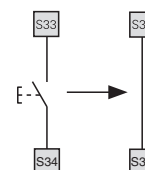

Monitored start

With regard to the indicated diagrams, remove the connection between S22 and S35 in order to activate the monitored start module.

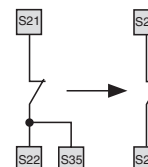

Electromechanical switches

The safety module can control both magnetic sensors and electromechanical switches. Replace the sensor contacts with switch contacts.

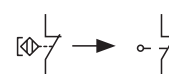

Dimensional drawings, housings features

Design A, housing width 22.5 mm

Connection data

Terminal tightening torque: 0.5 ... 0.6 Nm
 Cable cross section: 0.2...2.5 mm²
 24...12 AWG

Installation

Snap-mounting on DIN rails

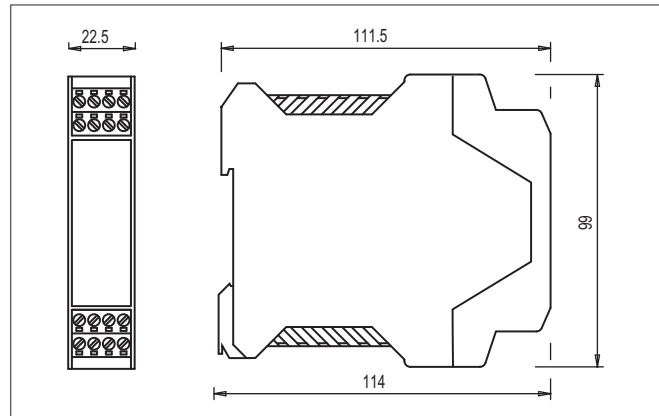

Connector with screw terminals

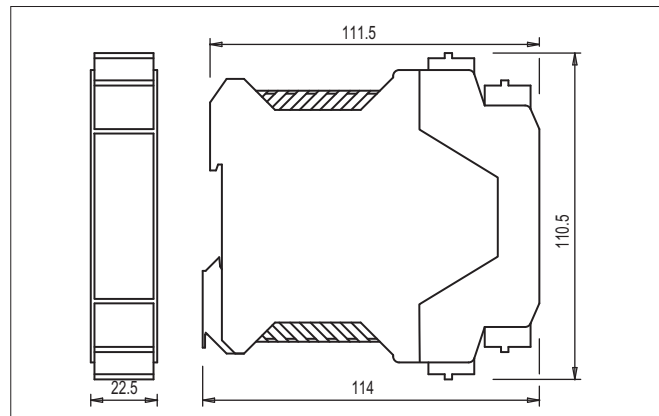

Connector with spring terminals

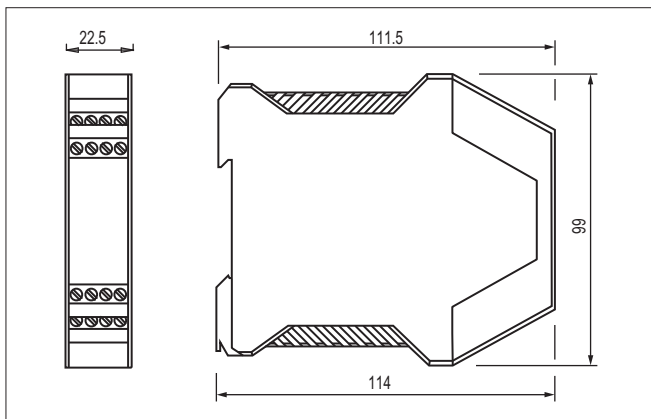

Screw terminals

Design D, housing thickness 22.5 mm

Connection data

Terminal tightening torque: 0.5 ... 0.6 Nm
 Cable cross section: 0.2...2.5 mm²
 24...12 AWG

Installation

Snap-mounting on DIN rails

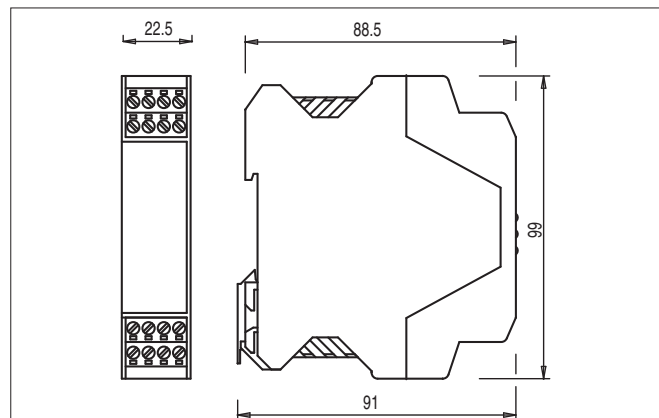

Connector with screw terminals

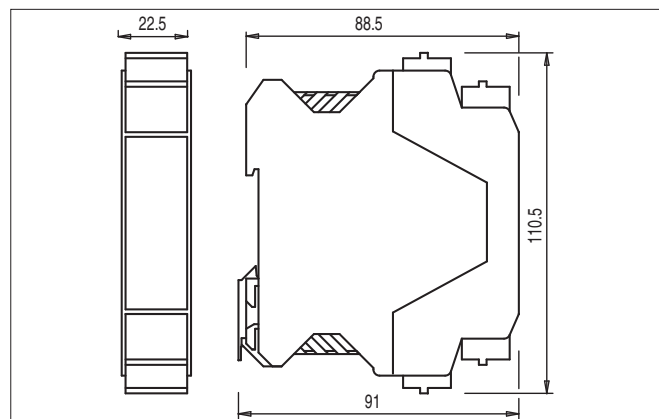

Connector with spring terminals

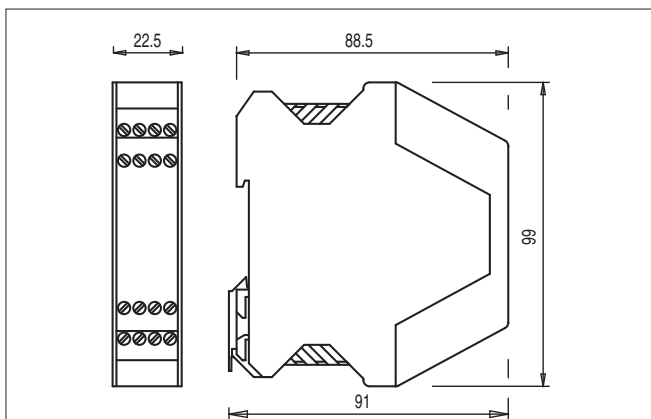

Screw terminals

All values in the drawings are in mm

→ The 2D and 3D files are available at www.pizzato.com